

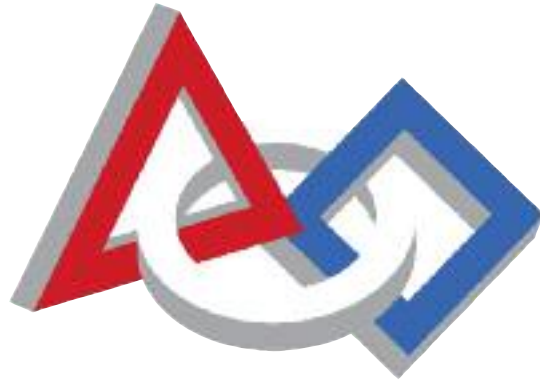

# Product Data Guide

***FIRST<sup>®</sup> Robotics Competition 2013***



***Want to use igus<sup>®</sup> products in  
your robot design?***

***Look Inside!***



**(800) 521-2747**

**[www.igus.com](http://www.igus.com)**

**E-mail Michael Hardy at  
[mhardy@igus.com](mailto:mhardy@igus.com)**

All products listed are donated to every participating *FIRST* team  
courtesy of igus<sup>®</sup> Inc.

## How to Use igus® Products on Your *FIRST* Robot

Hello FRC teams! Enclosed in this kit are a number of igus® products to help with the design of your *FIRST* robot. However, are you unsure about how to use igus® products? Read on for product information and some insightful tips and suggestions!

If you have additional questions, please contact Michael Hardy at [mhardy@igus.com](mailto:mhardy@igus.com).

In this kit, you will find:

### Energy Chain® Cable Carrier

Energy Chains® are all-plastic cable carriers designed to guide and protect cables in moving applications. Although the cables on your *FIRST* robot won't be moving, Energy Chain® is perfect for preventing cables from snagging or getting caught on opponents robots.

➡ **Looking for product specifications? See page 4.**

### DryLin® N Linear Guide Systems

DryLin® N low-profile linear guides are an oil-free alternative to bulky, messy ball bearings. DryLin® N has excellent wear resistance and a small mounting height and width, which is perfect when dealing with space constraints on your robot. Use DryLin® N to enable any linear movement your robot has to perform.

➡ **Looking for product specifications? See page 5.**

### DryLin® S Aluminum Shafting

DryLin® S aluminum shafting is lightweight and highly wear-resistant. It also has a lower coefficient of friction and delivers three times the life of steel when running against the proper bearing material. DryLin® S is the perfect partner for the plain, clip and spherical bearings also included in your kit.

➡ **Looking for product specifications? See page 6.**

### iglide® Clip Bearings

iglide® clip bearings are designed specifically for a variety of sheet metal applications. The bearings have flanges located on both ends so they can be secured in the sheet metal plate. After installation, the bearing opens and forms a lining for the borehole in the metal plate. The shafting prevents the clip bearing from detaching from the housing, even during axial movement.

➡ **Looking for product specifications? See page 6.**

### iglide® J Plastic Plain Bearings

iglide® J plastic bearings are an ideal alternative to bronze, metal-backed and custom injection-molded bearings. They are perfect for reducing the weight of your robot. iglide® J bearings are also self-lubricating, which means they require no maintenance or messy oils.

➡ **Looking for product specifications? See page 7.**

### iglide® M250 Plastic Plain Bearings

iglide® M250 plastic bearings are an ideal replacement for sintered-bronze bearings. They are impact-resistant and provide excellent vibration dampening. They are also dirt- and dust-resistant and are well suited for low to medium loads.

➡ **Looking for product specifications? See page 8.**

### igubal® Rod Ends and Flange Bearings

igubal® rod-end and flange bearings are maintenance-free and weigh only a fifth of traditional metallic rod-end bearings. This is a very popular product among *FIRST* teams, as these bearings also compensate for misalignment errors.

➡ **Looking for product specifications? See page 9.**

Good luck in this year's competition!

**Visit [www.igus.com](http://www.igus.com) to access free 3D CAD files, watch videos, access catalog pages, and more!**

igus, Energy Chain, DryLin, iglide, igubal, Chainflex, and ReadyChain are registered trademarks of igus Inc.  
All other company names and products are registered trademarks of their respective companies.

# Energy Chain® Cable Carrier Overview



## Series 05 E2 “micro” Data Sheet

Part Number: 05-4-038-0

Quantity: 1 meter

### When to use:

- when cables are vulnerable to damage
- to prevent cables from snagging or catching on other robots
- to organize the different types of cables used on your robot

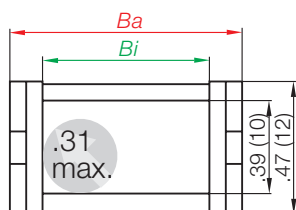

### Product Range:

Inner Widths (Bi) inches (mm):	.79 (20)
Bending Radii (R) inches (mm):	1.50 (038)
Pitch:	.79 (20 mm/link) =
	15.24 links/ft (50 links/m)

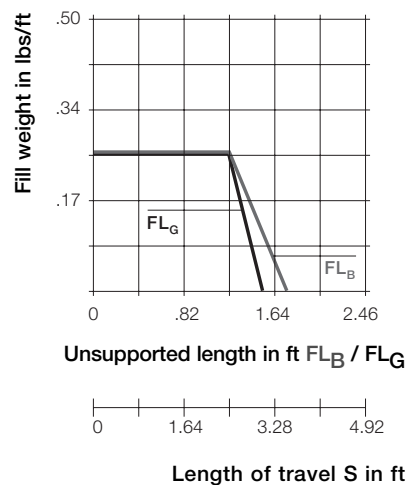

## Installation Dimensions

R	1.50 (038)	*The required clearance height is $HF = H + .39 (10)$ with .13 lbs/ft (0.2 kg/m) fill weight. Please consult igus® if space is particularly restricted.
H*	3.54 (90)	
D	2.36 (60)	
K	6.30 (160)	

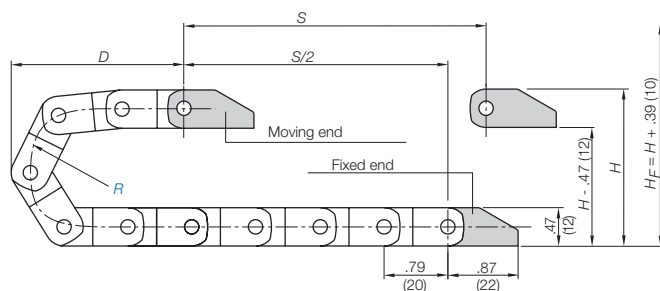

## Mounting Brackets

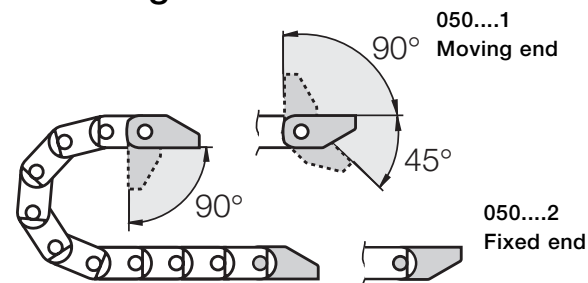

Chain Type	Part No. Full set	Dimension A		Dimensions B	
		in.	(mm)	in.	(mm)
05-20 (05-4)	050-20-12	-		.97	(24.7)

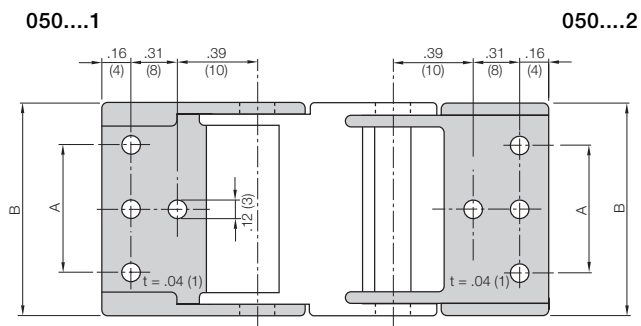

# DryLin® N Linear Guide System Overview



## DryLin® N Data Sheet

Part Number: NK02-40-2-610  
 (24 inches - 610 mm)  
 Quantity: 1 assembly

### When to use:

- for linear motion
- to save space
- for high speeds and accelerations



Application pictured uses the larger size of the DryLin® N product line.

### Special Characteristics of DryLin® N:

- maintenance-free and self-lubricating
- high resistance to dirt
- corrosion resistant
- lightweight due to aluminum/plastic combination
- very high speed and acceleration possible
- replaceable plastic sliding elements made of iglide® J

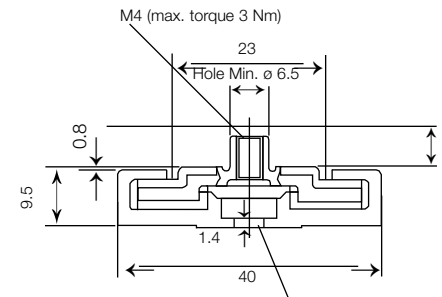

for Machine Screws M4  
 DIN 7984/DIN 6912/DIN 84  
 EN ISO 1707/EN ISO 7045

### Data

- Rail weight 3.12 oz/ft (290 g/m)
- Carriage weight .38 oz (10.8 g)
- Maximum rail length 11.5 ft (3000 mm)
- Standard bore scheme symmetrical C5=C6
- Maximum speed 49 ft/s

### Carriages with mounting nuts

### Load Data:

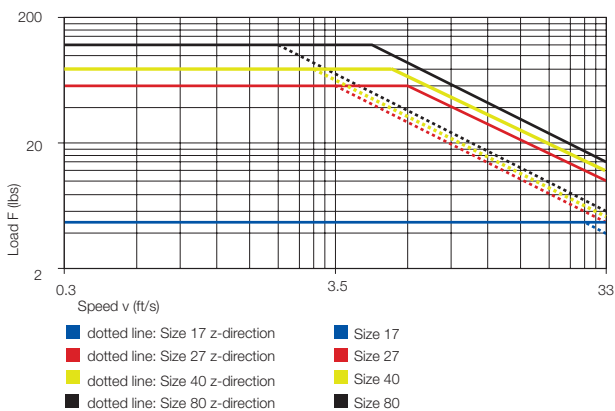
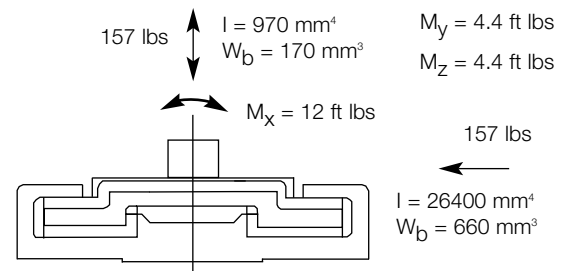

F = total of the loads on one rail

Fv-Diagram, maximum permissible dynamic loads of DryLin® N

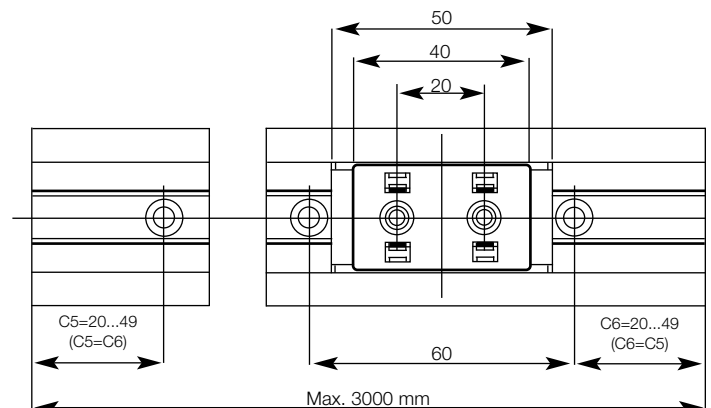

# DryLin® S Aluminum Shafting Overview



## DryLin® S Shafting Data Sheet

Part Number: AWI-10 (24 inches)

Quantity: 2

### When to use:

- in conjunction with igus® plain, clip and spherical bearings
- to reduce the weight of your robot

### Data:

Material: AlMgSi 0.5 F22

Tolerance: h9-h11

Roundness: DIN 1798

Straightness: DIN 1798

Hardness: 75 HB

Surface: hard-anodized/oxidation  
(wear-resistant Al-oxide)

Layer Thickness: > 40 µm

Surface Hardness: 450-550 HV

Roughness: Ra < 0.5

Electrical Resistance:  $4 \cdot 10^{11}$  Ohm mm<sup>2</sup>/m

Chemical Resistance:  $2 < \text{pH} < 9$

Part Number	Design	Diameter	Max. Length	Weight (lbs/ft)
AWI-10- L in mm	Solid	5/8	72	.361

# iglide® Clip Bearing Overview



## iglide® MCI Bearing Data Sheet

Part Number: MCI-06-01

Quantity: 4 (Extra parts are available through *FIRST* Choice)

### When to use:

- for slow rotating, oscillating or axial motion
- to reduce friction
- for quick and easy installation

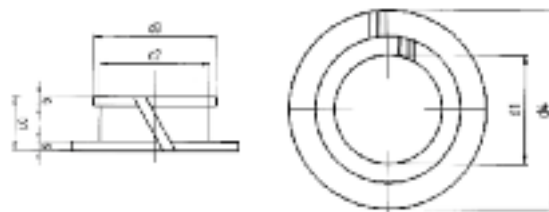

Part Number	Recommended Housing Bore		Recommended Shaft Size	
	Max.	Min.	Max.	Min.
MCI-06-01	0.4481	0.4375	0.3750	0.3740

Part Number	d1	d2	d3	d4	s	b1	ID of Bearing in Housing	Recommended Sheet Metal Thickness
MCI-06-01	3/8	0.4375	15/32	9/16	0.032	0.1380	.3760	.040/.075

# iglide® J Plain Bearing Overview



## iglide® J Bearing Data Sheet

Part Number: JSI-1012-08

Part Number: JFI-1012-08

Quantity: 2 of each (Extra parts are available through *FIRST Choice*)

### When to use:

- for rotational, oscillating and linear motion
- to reduce the weight of your robot
- for low wear against different shaft materials
- to eliminate the need for lubricants

### Special Characteristics:

- low coefficients of friction
- vibration dampening
- good chemical resistance

Part No.	d1	d2	b1	I.D. After Pressfit		Housing Bore		Shaft Size	
				Max.	Min.	Max.	Min.	Max.	Min.
JSI-1012-08	5/8	3/4	1/2	.6297	.6270	.7510	.7500	.6250	.6240

Part No.	d1	d2	b1	d3	b2	I.D. After Pressfit		Housing Bore		Shaft Size	
						Max.	Min.	Max.	Min.	Max.	Min.
JFI-1012-08	5/8	3/4	1/2	1.000	-.0055	.6297	.6270	.7510	.7500	.6250	.6240

## iglide® J Material Table

General Properties	Unit	iglide® J	Testing Method
Density	g/cm <sup>3</sup>	1.49	
Color		yellow	
Max. moisture absorption at 73°F/50% r.h.	% weight	0.3	DIN 53495
Max. moisture absorption	% weight	1.3	
Coefficient of friction, dynamic against steel	μ	0.06 - 0.18	
p x v value, max. (dry)	psi x fpm	9,700	

### Mechanical Properties

Modulus of elasticity	psi	348,100	DIN 53457
Tensile strength at 68°F	psi	10,590	DIN 53452
Compressive strength	psi	8,702	
Permissible static surface pressure (68°F)	psi	5,076	
Shore D-hardness		74	DIN 53505

### Physical and Thermal Properties

Max. long-term application temperature	°F	194	
Max. application temperature, short-term	°F	248	
Min. application temperature	°F	-58	
Thermal conductivity	W/m x K	0.25	ASTM C 177
Coefficient of thermal expansion (at 73°F)	K <sup>-1</sup> x 10 <sup>-5</sup>	10	DIN 53752

### Electrical Properties

Specific volume resistance	Ωcm	> 10 <sup>13</sup>	DIN IEC 93
Surface resistance	Ω	> 10 <sup>12</sup>	DIN 53482

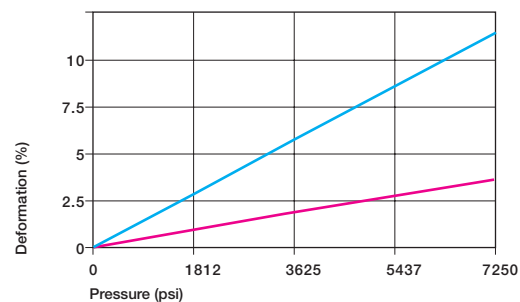

Deformation under load and temperature

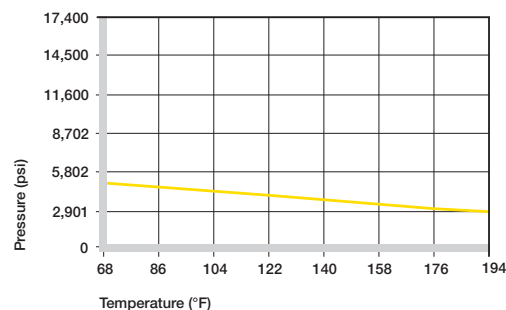

Recommended maximum permissible static surface pressure of iglide® J as a result of the temperature

# iglide® M250 Plain Bearing Overview



## iglide® M250 Bearing Data Sheet

Part Number: MTI-10

Quantity: 2 (Extra parts are available through *FIRST* Choice)

### When to use:

- for rotational, oscillating motions
- in place of bronze bearings to save weight and eliminate lubrication
- for dirty environments
- to reduce vibration

### Special Characteristics:

- dimensionally interchangeable with many sintered metal bearings
- excellent where high vibration dampening is necessary
- good for edge loads

## Dimensions (inches)

Part Number	d1(nominal)	d1		d2		s
		Max.	Min.	Max.	Min.	
MTI-10	5/8	.6371	.6300	1.0000	.9870	.0940

## iglide® M250 Material Table

General Properties	Unit	iglide® M250	Testing Method
Density	g/cm <sup>3</sup>	1.14	
Color		charcoal	
Max. moisture absorption at 73°F / 50% r.h.	% weight	1.4	DIN 53495
Max. moisture absorption	% weight	7.6	
Coefficient of friction, dynamic against steel	μ	0.18 - 0.40	
p x v value, max. (dry)	psi x fpm	3,400	

### Mechanical Properties

Modulus of elasticity	psi	391 600	DIN 53457
Tensile strength at 68°F	psi	16,240	DIN 53452
Compressive strength	psi	7,542	
Permissible static surface pressure (68°F)	psi	2 901	
Shore D-hardness		79	DIN 53505

### Physical and Thermal Properties

Max. long-term application temperature	°F	176	
Max. application temperature, short-term	°F	338	
Min. application temperature	°F	-40	
Thermal conductivity	W/m x K	0.24	ASTM C 177
Coefficient of thermal expansion	K <sup>-1</sup> x 10 <sup>-5</sup>	10	DIN 53752

### Electrical Properties

Specific volume resistance	Ωcm	> 10 <sup>13</sup>	DIN IEC 93
Surface resistance	Ω	> 10 <sup>11</sup>	DIN 53482

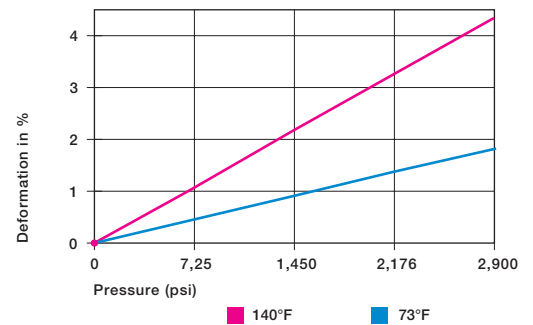

Deformation under load and temperature

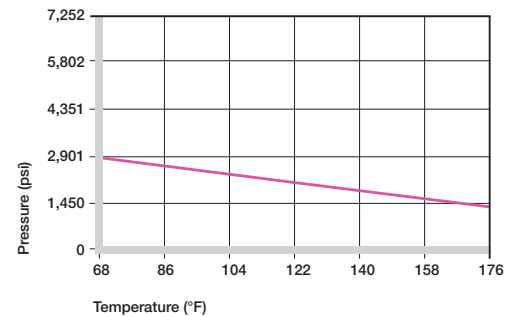

Recommended maximum permissible static surface pressure of iglide® M250 as a result of the temperature

# igubal® Rod Ends

## igubal® Rod End Data Sheet

Part Number: EBRI-10R

Quantity: 2 (Extra parts are available through *FIRST* Choice)



### When to use (both rod end and flange types):

- for rotational, oscillating and linear motions
- to compensate for misalignment and edge loads
- to reduce the weight of your robot — weighs 1/5 of metallic bearings

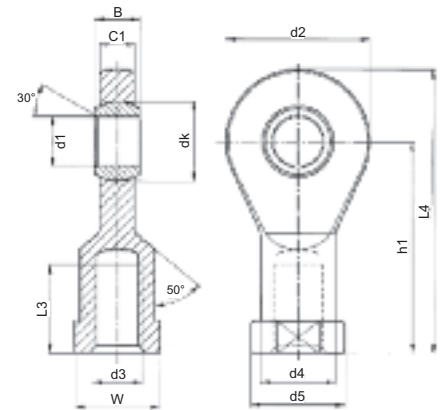

### Special Characteristics of EBRI-10R:

- maintenance-free, self-lubricating
- high strength under impact loads
- very high tensile strength for varying loads
- resistant to dirt, dust and lint
- resistant to corrosion and chemicals
- high vibration dampening capacity

### Load Data and Dimensions (inches)

Right-Thread	Left-Thread	Max. static Tensile Strength		Max. Cross Force		Min. Thread Depth (mm)	Max. Torque Strength Outer Threading (ft lbs)	Max. Torque Strength Through Ball (ft lbs)
		Short-term (lbs)	Long-term (lbs)	Short-term (lbs)	Long-term (lbs)			
EBRI-10R	EBLI-10R	1079	539	180	90	18	18.4	22.1

Right-Thread	Left Thread	d1 E10	d2	d3	d4	d5	C1	B	h1	I3	I4	W	Max. Angle of Pivot
EBRI-10R	EBLI-10R	0.6250	1.693	5/8	.827	1.023	0.4134	0.5000	2.5394	1.0433	3.3858	0.87	16°

# igubal® Flange

## igubal® Flange Bearing Data Sheet

Part Number: EFOI-10R

Quantity: 2 (Extra parts are available through *FIRST* Choice)

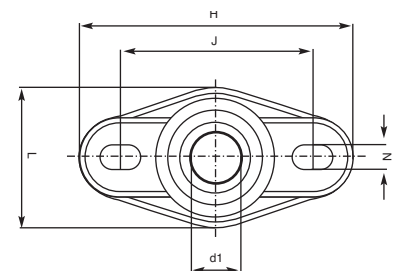
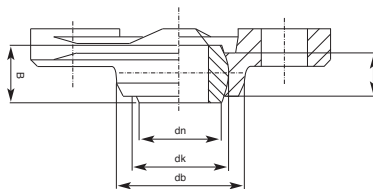
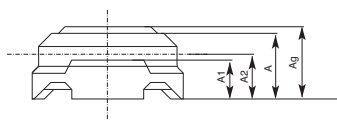

### Load Data and Dimensions (inches)

Part Number	N d x l	B	C1	Max. Angle of Pivot	Max. Permissible Load on the Spherical Ball (lbs)	Max. Permissible Tensile Strength Force (lbs)
EFOI-10R	0.212 x 0.315	.500	0.374	24°	315	629

Part Number	d1	dn	dk	dB	H	L	J	A1	Ag	A	A2
EFOI-10R	.6250	.512	.630	1.260	2.858	1.496	2.087	.394	.683	.622	.433

## DryLin® W



### DryLin® W Rail

Part Number: WS-10-40

### DryLin® W Zinc Carriage

Part Number: WW-10-40-10

#### When to use:

- Double rail system reduces assembly time and increases rigidity
- No need for rail alignment
- Pre-assembled carriage for easy assembly

## DryLin® W



### DryLin® W Rail

Part Number: WSQ-10

### DryLin® W Zinc Carriage

Part Number: WJ200QM-01-10

#### When to use:

- Single profiles for maximum flexibility, can be oriented in multiple ways
- Square profile easily compensates for misalignments making assembly easier
- More surface area on square profile for maximum bearing life

## iglide® PRT



### iglide® PRT

Part Number: PRT-01-30

#### When to use:

- Maintenance- and lubrication-free
- Ready to fit
- Robust and corrosion-resistant



# igus®

## *Facts At A Glance*

**Corporate Mission** igus® is committed to manufacturing plastic components which enhance the performance and prolong the life of automated machinery, and meet the needs of all of its customers, both professional and student alike.

**Tag Line** plastics for longer life®

**Founded** 1985 US headquarters established in East Providence, R.I.  
1964 Cologne, Germany

### ***Innovation with Plastics***

High-performance plastic bearings have emerged as a viable, cost-effective alternative to metal plain bearings as a standard choice for design engineers. Engineers are realizing that advanced synthetic compounds provide more design opportunities than traditional materials. For more than 40 years, igus® has been developing bearing materials based on modern plastics, which have predictable tribologic properties: fiber for reinforcement and strength, a lubricant and a base material.

Due to their plastic composition, all igus® bearings are lubrication-free and require no maintenance. The plastic-based construction also eliminates corrosion, delivers better vibration dampening than metal bearings, handles edge loading better than metal-backed, has high shock absorption, and emits low noise.

igus® plastics are also used throughout the Energy Chain® product line. By using only plastic, these cable carriers are lightweight, yet provide the same protection as steel or plastic/steel combination carriers.

Today igus® offers 28 high-performance plastic material blends. All have been developed through years of detailed research and rigorous testing. This commitment to quality has propelled the company to the forefront of the motion-control industry and will continue to lead igus® to success in the future.

### ***Products***

igus® develops an array of machinery components in addition to the products enclosed in your *FIRST* kit (see data sheets included in this brochure for details on those products), including:

- **Chainflex® cables** - specifically designed for use in Energy Chain Systems®, which can withstand the stress of tight bending radii and deliver longer extended life.
- **ReadyChain®** - preassembled cable-carrier systems complete with cables, Energy Chains®, connectors and accessories, which are custom-designed to the customers' specifications to deliver a ready-to-install, fully harnessed, out-of-the-box solution.

# The Y.E.S. (Young Engineers Support) Program

igus® Inc., the leading developer of Energy Chain Systems®, Chainflex® continuous-flex cables and iglide® plastic bearings, offers free products through its Y.E.S. (Young Engineers Support) Program, which is designed to foster the mechanical design ideas of students who have a passion for engineering.

Through the Y.E.S. Program, igus®:

- offers free product donations to students, engineers, teachers and professors for use in various design competitions, school projects and engineering curriculums.
- offers in-class seminars about igus®, its products and the various ways students can take advantage of the Y.E.S. Program.
- educates students and engineers alike on the merits and benefits of plastic components.
- supports the visions of various engineering competitions by donating products, technical support and other resources.
- revitalizes students' interest in engineering.
- aids in making the unique design ideas of students and engineers a reality.
- encourages students to implement igus® products into their projects in unique, interesting ways.
- reaches students from across the United States, Canada and Mexico.

**For information contact Michael Hardy, Y.E.S. Program Administrator,  
at 800-521-2747 ext. 146 or visit [www.igus.com/yesprogram](http://www.igus.com/yesprogram).**

## Y.E.S. Facts

- The Y.E.S. Program is open to students of all ages and grade levels, as well as teams and engineers competing in robotics competitions.
- Through the Y.E.S. Program, igus® is a product sponsor of the FIRST® Robotics Competition and has various products included in more than 2,300 consumable parts kits.
- The Y.E.S. Program sponsors additional competitions such as BEST™ Robotics, Botball®, the Rube Goldberg contest, NASA's Lunabotics Mining Competition and the SAE Collegiate Design Series.
- Students have the opportunity to have their accomplishments featured on the Y.E.S. website by submitting information about the unique application, how they used igus® products and pictures.